



See
initial start-up
instructions on page one

**COMMERCIAL
PRODUCTS™**

**Iron & Oak 20 Ton
Tractor Mount
Vertical / Horizontal Log Splitter**

**Models TMVH02/PTO
TMVH03/HYD**

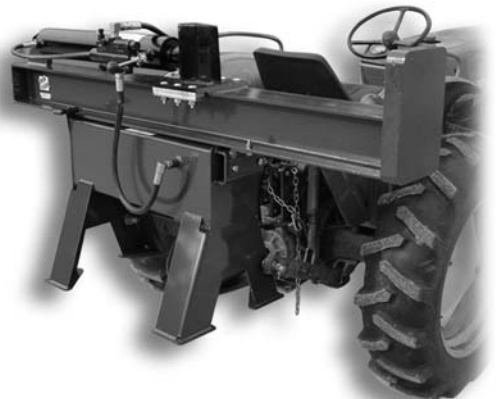

**Owner / Operator
and Safety Manual**

 **Made in U. S. A.**

Initial Start-Up Instructions

- Read all assembly, operating, and safety instructions.
- Complete and return the warranty card to register your log splitter.
- Write the serial number and date-of-purchase in this manual.
- Assemble the log splitter.
- Fill the hydraulic tank with the recommended type and quantity of oil. (See “Start-Up Procedure” section.)
- Bleed the air out of the cylinder before using the log splitter. (See “Start-Up Procedure” section.)

NOTE: Iron and Oak Commercial Products reserves the right to make technical changes for product improvement. This manual may contain illustrations and photographs, for demonstration purposes, which slightly deviate from the actual product design.

Serial Number _____

Date-of-Purchase _____

Please enter the serial number and purchase date of your log splitter in the space provided. Keep this manual for future reference.



IRON & OAK

BRAVE
PRODUCTS, INC.
Streator, IL

SERIAL No.

Made in U.S.A.

Contents

Introduction	4
Safety	5
Personal Protection	5
Worksite Safety	5
Operating Safety	6
Log Splitting Safety	7
Maintenance and Repair	8
Assembly Instructions	9
Required Tools	9
Shipping List	9
Unpacking the Crate	10
Assembly and Initial Installation Procedure	11
Start-Up Procedure	16
Model TMVH02/PTO	16
Model TMVH03/HYD	17
Operation	18
Operation - Horizontal Position	19
Operation - Vertical Position	22
Inspection and Maintenance	25
General Maintenance Check (before operating)	25
Storage	25
Specifications	26
Mechanical Specifications	26
Hydraulic Specifications (Model TMVH02/PTO)	26
Hydraulic Specifications (Model TMVH03/HYD)	26
Hydraulic Oil Specifications (non foaming)	26
Troubleshooting	27
Decals	28
Parts	30
Model TMVH02/PTO	30
Model TMVH03/HYD	32
Warranty	36
Warranty Card	37
Optional Attachments	39
Log Dislodger	39

WARNING



To avoid personal injury or death, carefully read and understand all instructions pertaining to the Iron & Oak Commercial Products' log splitter.

Do not attempt to assemble, operate, or maintain our product without fully understanding all our instructions and safety precautions. Do not operate the log splitter unless you read and understand the instructions and warnings in this manual. If any doubt or question arises about the correct or safe method of performing anything found in this or other Iron & Oak Commercial Products' manuals, contact your Iron & Oak Commercial Products' dealer or call the Sales and Service representatives at our main headquarters. Proper care is your responsibility.

WARNING

Accidents can often be avoided by being alert and recognizing potentially hazardous situations. Any individuals operating, maintaining, or repairing products manufactured by Iron & Oak Commercial Products should have the necessary training, skills, and tools required to perform these functions properly and safely. The safety information in this manual serves as a basic guide in an attempt to prevent injury or death.

Iron & Oak Commercial Products cannot anticipate every possible circumstance that might involve a potential hazard. The warnings in this manual and on the product itself are, therefore, not all inclusive. If tools, procedures, work methods, or operating techniques that are not specifically mentioned by Iron & Oak Commercial Products are used, you must satisfy yourself that they are safe for you and for others. Make sure the log splitter will not be damaged or made unsafe by any operation, lubrication, maintenance, or repair procedures that you choose.

DO NOT proceed if any doubt arises about the correct or safe method of performing anything found in this or other Iron & Oak Commercial Products' manuals. Seek out expert assistance from a qualified person before continuing.

Introduction

These commercial TMVH02/PTO and TMVH03/HYD Vertical/Horizontal Tractor Mount Log Splitters are designed for tough applications in both vertical and horizontal positions. With up to 20 tons of splitting force, the TMVH02/PTO and TMVH03/HYD will handle most of your commercial log splitting needs. The log splitter attaches to any tractor with a class 1, 2, or 3 three-point hitch.

Power for the TMVH02/PTO is provided by a hydraulic PTO pump which connects directly to the tractor's PTO shaft. Power for the TMVH03/HYD comes directly from tractor supplied hydraulic pressure. The maximum splitting force is determined by the pressure output of the tractor's hydraulic system. For example, 3000 psi of pressure produces 20 tons of splitting force, 2000 psi produces 12.5 tons, and 1500 psi produces 9 tons.

An attractive, powder-coated finish provides the finest protection available and Iron & Oak's rigid, quality-control and component testing help ensure years of productive, reliable service. Since 1982, the name Iron & Oak has stood for quality and reliability when it comes to log splitters and wood processing products.

Iron & Oak Commercial Products offers the finest commercial log splitter on the market today!







- ✓ Rugged, heavy-duty construction for years of exceptional service.
- ✓ Ergonomic design for use in vertical and horizontal operating positions.
- ✓ Fits category 1, 2, and 3 tractor hitches.
- ✓ Rigid, quality-control during manufacturing ensures greater reliability.
- ✓ Factory testing of all major components and hydraulic tank.
- ✓ Powder-coated finish for the best appearance and weather protection.
- ✓ Year-round manufacturing, parts, and support.

For additional information, contact us at:







Iron & Oak Commercial Products
410 W. Broadway Ave.
P.O. Box 577
Streator, Illinois 61364-0577
Phone: (815) 672-8596
Fax: (815) 672-9073
E-mail: sales@logsplitters-ironoak.com
Web Site: www.logsplitters-ironoak.com

The following is a list of safety rules you must follow in order to use your log splitter safely.

Personal Protection











- ✓  To avoid personal injury or death, carefully read and understand all instructions pertaining to the log splitter including the engine manufacturer's operating and maintenance instruction manual.
- ✓      Always wear protective gear, such as safety goggles, tight-fitting gloves without draw strings or loose cuffs, steel-toed shoes, and a protective hearing device.
- ✓  To prevent injury, make sure all decals are attached to the log splitter and are legible at all times.









Worksite Safety

- ✓  To avoid tripping, do not leave tools, logs, or other components laying around in the work area.
- ✗  NEVER operate your log splitter on slippery, wet, muddy, or icy surfaces. The location you choose should be flat, dry, and free from any tall grass, brush, or other interferences.
- ✗  NEVER operate the tractor in an enclosed area. Exhaust fumes contain carbon monoxide which can be deadly when inhaled. Make sure the area is well ventilated.
- ✗  NEVER use your log splitter at night.
- ✓  ALWAYS operate your log splitter on dry, solid, level ground.
- ✓  ALWAYS engage the parking brake and block the wheels of the tractor to prevent movement while operating the log splitter.
- ✓  Sudden movement or accidental starting of the tractor can cause personal injury or death to persons on or near the tractor. When working on or near the tractor, park the tractor on a smooth level surface, stop the engine, and engage the parking brake.





Safety

Operating Safety

- ✓  ALLOW ONLY ONE (1) PERSON TO LOAD AND OPERATE THE LOG SPLITTER.
- ✓  Allow only adults to operate the log splitter. No one under the age of 18 should be allowed to operate the log splitter.
- ✓  Always keep bystanders, including children and pets, at least twenty-five (25) feet away from the work area. Only the operator should stand near the equipment, and the operator should stand only within the safe operating zone prescribed in this manual (see the photos on safe and unsafe operating zones in the “Operation” section).
- ✓  When the ram of the log splitter is in the return mode, keep your hands off the machine — the log splitter is designed to automatically stop when the cylinder is fully retracted.
- ✓  Personal injury or death can result from not engaging the tractor’s parking brake while attaching the log splitter. If the parking brake is not engaged, the tractor may roll while you are on or near the tractor. Always engage the parking brake before leaving the tractor.
- ✓  Personal injury could result from an improperly coupled log splitter. Be certain draft links, top link, and hitch pins are fully engaged on both sides before using the log splitter.
- ✓  An improperly installed log splitter could become dislodged from the tractor during operation. This could cause injury or death. Do not operate the tractor until you are sure the log splitter attachment is properly connected.
- ✓  Heavy 3-point hitch mounted equipment reduces road stability, regardless of the amount of front-end counterweight added. Insufficient roading stability can lead to an accident, causing personal injury and property damage. Reduce speed when encountering rough terrain or whenever the tractor’s directional stability is reduced.
- ✗  Do not allow any person to operate the log splitter until they have read and understood the safe operating instructions contained in this manual.
- ✗  Machine instability can result in injury or death. To ensure stability during operation do not overload the tractor and follow all the tractor’s manufacturers safety recommendations.







- ✘  Do not, under any circumstances, alter your log splitter. This equipment was designed and engineered to be used in accordance with the operating instructions. Altering the equipment, or using the equipment in such a way as to circumvent its design capabilities and capacities, could result in serious or fatal injury and WILL VOID THE WARRANTY.
- ✘  Never operate, or allow anyone else to operate, this equipment while under the influence of medication, drugs, or alcohol.
- ✘  Never wear loose clothing or jewelry that may get caught or become entangled in the log splitter.
- ✘  NEVER place hands or feet between log and splitting wedge or between log and ram during the forward or reverse stroke.
- ✘  DO NOT STRADDLE OR REACH ACROSS THE SPLITTING AREA WHEN OPERATING THE LOG SPLITTER.
- ✘  Do not step over your log splitter when the tractor is running, because you may trip or accidentally engage the ram.
- ✘  NEVER attempt to load your log splitter while the ram is in motion.
- ✘  Only use your hand to operate the control lever. NEVER use your foot, knee, a rope, or any other extension device.

Log Splitting Safety

- ✓  Always keep your fingers away from any cracks that open in the log during the splitting operation.
- ✓  ALWAYS make sure that both ends of the log you are splitting are cut as square as possible. This will prevent the log from sliding out of position while under pressure. Logs should be 24 inches or shorter in length.
- ✘  NEVER try to split two logs on top of each other.
- ✘  Never pile logs to be split in a manner that will cause you to reach across the log splitter.

Safety

Maintenance and Repair

- ✓  Follow all safety rules, because most accidents involving the operation, maintenance, or repair of products occur because the assembler/owner/operator failed to observe basic safety rules or operating instructions.
- ✓  ALWAYS inspect your log splitter before each use. Make sure all nuts, bolts, screws, hydraulic fittings, hose clamps, etc. are securely tightened.
- ✓  ALWAYS check the oil level in the hydraulic oil tank.
- ✗  NEVER operate your log splitter when it's in need of repair or is in poor mechanical condition.
- ✗  NEVER make alterations to your log splitter in any manner. Such alterations may cause the log splitter to become unsafe and **WILL VOID THE WARRANTY.**
- ✗  NEVER attach a rope or extension to the control lever or add width or height to the splitting wedge. Such **ALTERATIONS** may cause the log splitter to become **UNSAFE** and **WILL VOID THE WARRANTY.**
- ✗  ALWAYS clean the unit after each use. If possible, store the unit inside or cover it completely, if stored outside.

Assembly Instructions

Required Tools

- 10" crescent wrench
- Flat head screwdriver
- Funnel (PTO Model)
- Pliers
- Band cutters

Shipping List

The following charts contain the list of parts shipped with your log splitter.

TMVH02/PTO	
Qty.	Description
1	Base Unit ¹
1	Rail Unit (hydraulic cylinder) ¹
Rail to Base Assembly	
2	Bolts (1/2-13 x 1-1/2") ²
2	Lockwashers (1/2") ²
2	Nuts (1/2-13) ²
Power Take Off Pump	
1	PTO Pump with attached hoses ²
1	Chain ²
Valve Assembly	
1	Control Lever (valve) ²
1	Knob (valve lever) ²
1	Valve Link ²
3	Clevis Pins ²
3	Cotter Pins ²

¹ On the pallet.

² In cardboard box.

TMVH03/HYD	
Qty.	Description
1	Base Unit ¹
1	Rail Unit (hydraulic cylinder) ¹
Rail to Base Assembly	
2	Bolts (1/2-13 x 1-1/2") ²
2	Lockwashers (1/2") ²
2	Nuts (1/2-13) ²
Valve Assembly	
1	Control Lever (valve) ²
1	Knob (valve lever) ²
1	Valve Link ²
3	Clevis Pins ²
3	Cotter Pins ²

¹ On the pallet.

² Inside plastic bag.

Assembly Instructions

Unpacking the Crate

1. Cut the metal banding and remove the top, sides, ends, and protective plastic covering of the packing crate. Do not remove the base unit or the rail assembly from the bottom pallet at this time.

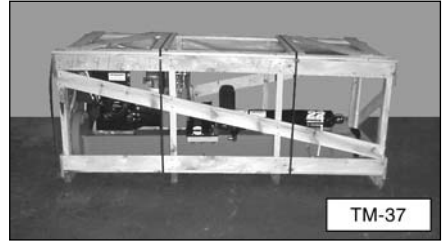

2. Carefully check the larger components on the shipping pallet for damage. If the parts are damaged call Iron & Oak Products at (815) 672-8596.

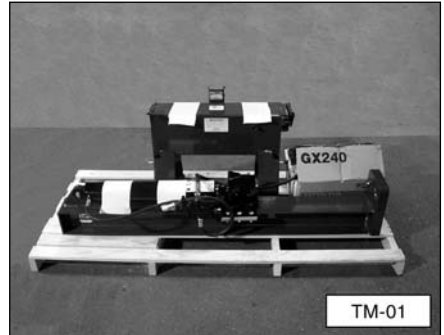

3. Cut all of the banding straps and open the cardboard box to make sure all the smaller parts have been shipped (PTO and chains are shipped with TMVH02/PTO models only). The chart in the "Shipping List" section provides a complete list of all the parts shipped with your log splitter. If any parts are missing call Iron & Oak Products at (815) 672-8596.

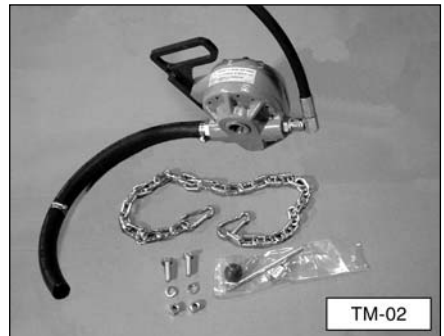

NOTE: The contents of the cardboard box contains the PTO pump with attached hoses and PTO mounting chain (model TMVH02/PTO only). Also, included in the box is a plastic bag of miscellaneous hardware and a plastic bag with the valve handle, knob, valve link, clevis pins, and cotter pins.

Assembly and Initial Installation Procedure

⚠ CAUTION



Some components are very heavy and can be damaged if mishandled. Also, to help prevent personal injury, it is strongly recommended that two (2) people work together to uncrate and assemble the log splitter.

1.  Remove and read all instructions and safety recommendations before assembling or operating this log splitter.
2. For model TMVH02/PTO remove the PTO pump from the box and hang it on the base unit hanger bracket, as shown.
3. Pull the spring-loaded locking lever outward and twist it either direction to lock it in the “unlocked” position.

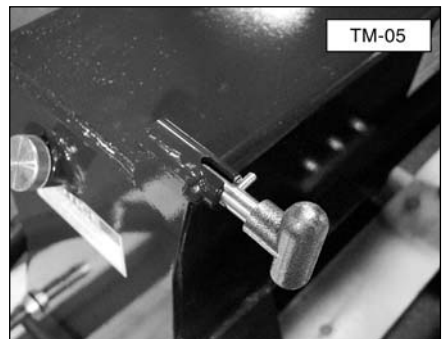

Assembly Instructions

- Using two people or a lifting device, set the rail assembly on top of the base unit. Position the rail assembly to align the mounting holes with the holes in the hinge (attached to base unit).

⚠ WARNING

Make sure the rail assembly is sitting securely on the base unit, on a flat, level area. The rail assembly weighs approximately 300 pounds and will cause bodily injury if it falls on someone.



- Turn the spring-loaded locking lever until the spring pin slides into the slot. This allows the plunger to snap into place, securing the rail assembly in a horizontal position.

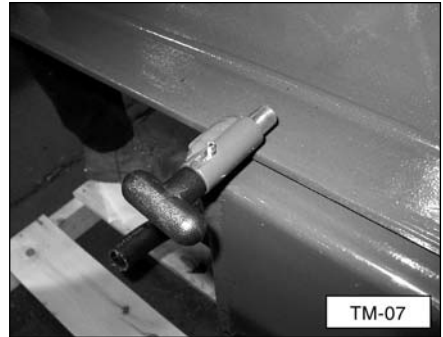

- Bolt the rail assembly to the base unit using two 1/2-13 x 1-1/2 inch long hex head bolts, lockwashers, and nuts, as shown. Tighten the nuts securely.



Assembly Instructions

7. Install the valve link onto the valve body, as shown, using a 1/4 x 1 inch long clevis pin. Secure the clevis pin with a cotter pin (bend the ends of the cotter pin to make it secure).

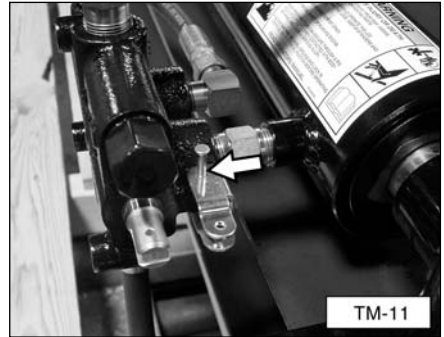

8. Install the valve handle onto the valve link using a 1/4 x 3/4 inch long clevis pin. Secure the clevis pin with a cotter pin (bend the ends of the cotter pin to make it secure).

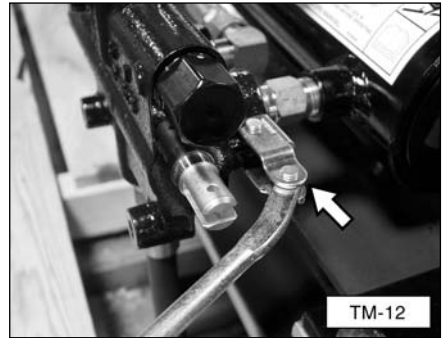

9. Attach the valve handle to the valve spool using a 1/4 x 1 inch long clevis pin. Secure the clevis pin with a cotter pin (bend the ends of the cotter pin to make it secure). Attach the knob to the valve handle, if necessary.



10. For model TMVH02/PTO apply a thread sealing material to the male end of the high-pressure hose from the bottom of the valve and attach the fitting to the hydraulic tank (base unit), as shown. Securely tighten the fitting.



Assembly Instructions

11. Attach the tractor mount log splitter to the 3-point tractor hitch, as shown, and according to the directions found in your tractor operating manual. (TMVH02/PTO model shown here.)

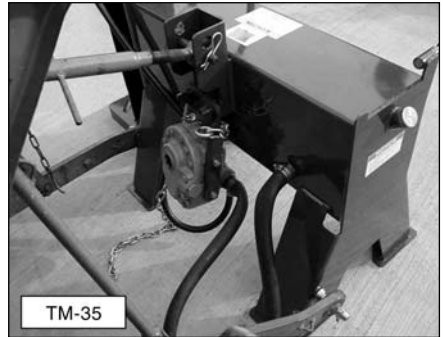

For model TMVH02/PTO follow Steps 12 through 16. For model TMVH03/HYD go to Step 17.

12. Remove the PTO pump from the hanger bracket of the base unit.

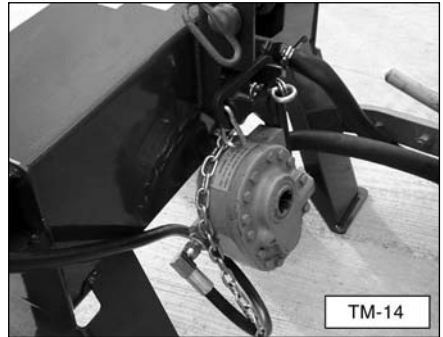

Before proceeding to Step 13, tractor's engine must be off and the parking brake set.

13. Slide the PTO pump onto the PTO shaft of the tractor. Make sure the rotation arrow on pump is facing rearward. Attach one end of the chain to the torque arm bracket and the other to a stationary part of the tractor (axle, 3 point arm, etc.). Make sure the chain does not interfere with raising and lowering the unit.

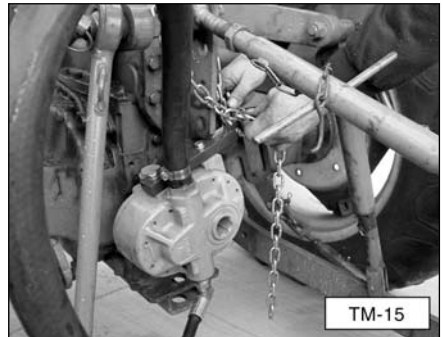

NOTE: On some tractors, a PTO shaft extension may be necessary in order to connect the PTO to the pump.

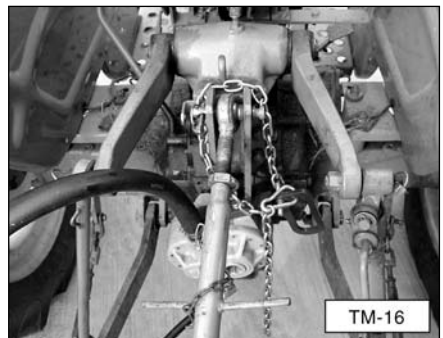

Assembly Instructions

14. Raise the log splitter to the maximum "carry height" to determine the full distance of movement.
15. Measure and cut the low-pressure hose to adequate length, making sure it does not stretch, bind, or kink when in either the carrying or working positions.
16. Lower the log splitter to the ground. Attach the low-pressure hose to the fitting near the bottom of the hydraulic tank (base unit). Tighten the hose clamp.

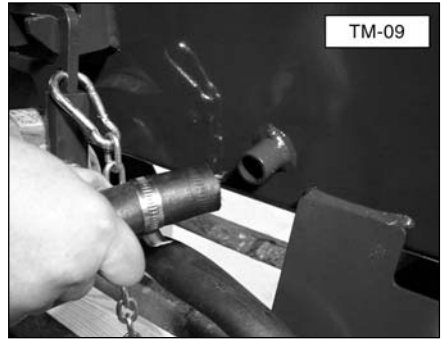
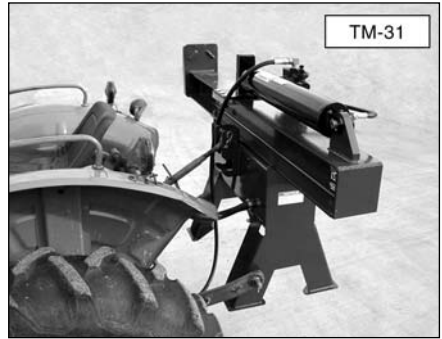

17. Connect one customer supplied 3/4 inch hydraulic hose from your tractor's hydraulic supply port to the top at the control valve. Connect the second hose from the tractor's return port to the bottom of the valve.

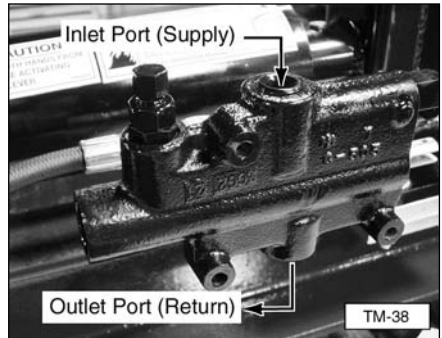

18. The log splitter is now completely assembled. **Follow the "Start-Up Procedure" in the following section, which adds oil to the hydraulic tank before running the PTO pump.**

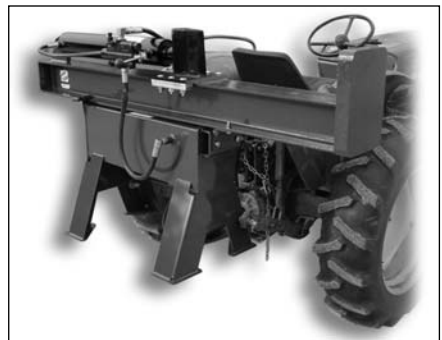

Start-Up Procedure

Model TMVH02/PTO

Important Notice

Do not run the PTO pump. Follow all the instructions in the “Start-up Procedure” before operating the log splitter. Failure to follow this recommendation will result in PTO pump damage.

IMPORTANT: Before operating the PTO, read the tractor manufacturer’s operating and maintenance instruction manual. If a manual is not available, it is your responsibility to obtain a manual from the tractor manufacturer.

1. Remove the fill cap and fill the hydraulic tank with SAE 10W tractor hydraulic oil or automatic transmission fluid, such as Dextron III. The tank is full when the oil level is at the bottom of the filler neck. Do not tighten the fill cap at this time.

NOTE: The total hydraulic system oil capacity for this unit is 9.5 gallons.

2. Lubricate the surface of slide rail with grease. This will help to prevent wear between the slide plates and the slide rail.
3. Slowly rotate the tractor’s PTO shaft to fill the PTO pump with oil.
4. Once the pump is primed (filled with oil) increase the rpm of the PTO shaft. Now, push the valve control handle to the forward position (towards the front of the cylinder) until the cylinder piston moves forward. (Keep everything away from the splitting wedge during this step.)

NOTE: Extending the cylinder piston draws the hydraulic fluid through the system and expels any trapped air in the system.

5. Cycle the log splitter several times.
6. Push the valve control handle to the retract position and retract the cylinder piston. The cylinder valve will automatically stop the cylinder from retracting when it reaches the end of its stroke.
7. Check the fluid level in the hydraulic tank and add oil as needed. Replace and tighten the fill cap.
8. Your log splitter is now ready to use.

Model TMVH03/HYD

1. Lubricate the surface of slide rail with grease. This will help to prevent wear between the slide plates and the slide rail.
2. Push the valve control handle to the forward position (towards the front of the cylinder) until the cylinder piston moves forward. (Keep everything away from the splitting wedge during this step.)
3. Cycle the log splitter several times.
4. Push the valve control handle to the retract position and retract the cylinder piston. The cylinder valve will automatically stop the cylinder from retracting when it reaches the end of its stroke.
5. Your log splitter is now ready to use.

WARNING



Do not attempt to operate the log splitter without fully understanding all our instructions, safety precautions, and/or warnings. If any doubt or question arises about the correct or safe method of performing anything found in this or other Iron & Oak Products' manuals, contact your Iron & Oak Products' dealer or call the Sales and Service representatives at our main headquarters. Proper care is your responsibility.

When operating the log splitter make sure you are standing in the **safe operating area**, as shown in these pictures. You must stay in the **safe operating area** at all times when the splitting wedge is in motion (whether extending or retracting). Never place any part of your body into a position which would cause an unsafe operating condition.

1. Place the tractor and log splitter on flat, dry ground. Make sure you read all recommendations from the "Safety" section before using the log splitter.
2. Make sure both ends of the log you are splitting are cut as square as possible. This will prevent the log from sliding out of position while under pressure. All logs should be 24 inches long or shorter.

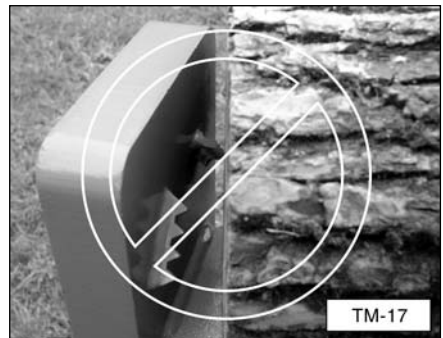

WARNING

Never attempt to split wood across the grain. The log splitter was not designed for cross-grain splitting. Doing so will damage the log splitter and may cause personal injury.

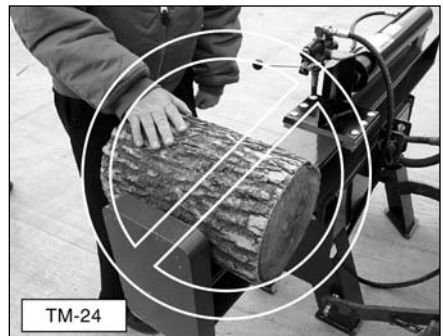

WARNING



Before loading and operating the log splitter, always wear protective gear, such as safety goggles, face shield, hearing protection,

tight-fitting gloves without draw strings or loose cuffs, and steel-toed shoes.

3. Start the tractor. Warm up the PTO pump and/or hydraulic system by running the engine at half throttle for 3 to 4 minutes, then advance the engine throttle control to maximum speed.

Operation – Horizontal Position

4. Use the following photos for the correct and incorrect methods of splitting logs. Never split a log using an incorrect or unsafe method.
 - a. Place the log on the log splitter. Grasp the log on the sides near the middle of the block. Center the log, side-to-side, on the rail of the log splitter, making sure that the sawed end is against the large plate (base plate) at the opposite end from the hydraulic control valve control lever.



CAUTION



Do not place your hands on the ends of the log when loading the log splitter. This is a very **UNSAFE** method and could result in injury to your hands.

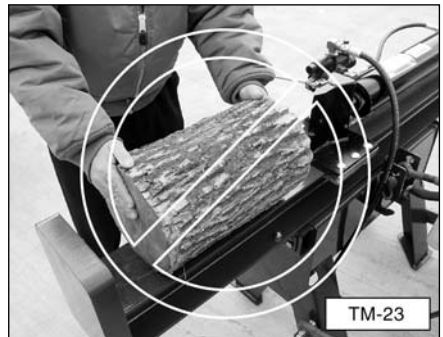

Operation

- b. Only using your hand, push the control lever forward (towards the log). If the log moves before it is contacted by the splitting wedge, release the control lever and then reposition the log. Operate the log splitter only when standing in the **safe operating area**, shown in the picture.



⚠ CAUTION



If you find you must hold the log until the wedge touches it and holds it in place, be very careful not to put your hand between the log and the end plate or the log and the wedge. If you must, hold the log on top and in the middle. Remove your hand immediately when the splitting wedge engages the log. Never use your hip or any extension device to operate the valve control handle.

⚠ WARNING



Do not operate the log splitter by reaching across the rail. This is a very **UNSAFE** method which could cause personal injury or even death.

⚠ WARNING



Do not reach or step across the rail while the log splitter is running. This is a very **UNSAFE** method which could cause personal injury or even death.

- c. Hold the control lever, extending the splitting wedge, until the log is split or the cylinder rod stops at its maximum travel position. As the log is being split, DO NOT reach forward and attempt to catch the split wood — let it fall to the ground.

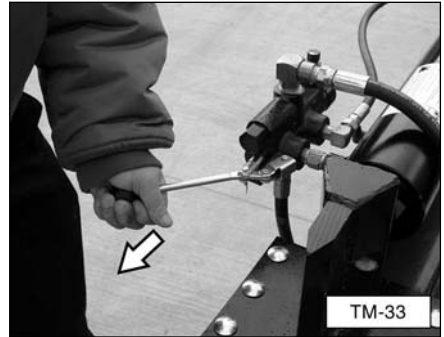

- d. Once the wedge reaches its full forward travel, pull back on the control lever to the full retract position. The ram of the cylinder will automatically retract into the cylinder. It is not necessary to hold the control lever as the cylinder retracts. Stop the wedge if the log sticks (see caution below). When the cylinder is fully retracted, the control valve will automatically shift to a neutral position.

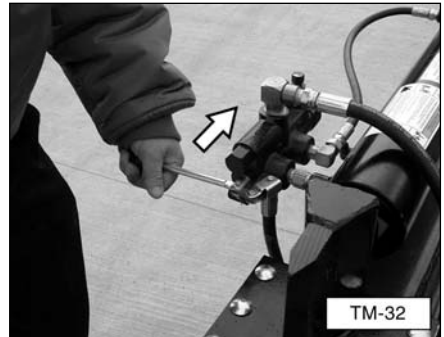

- e. DO NOT load another log or remove split pieces from the rail until the wedge has completely stopped and the control handle automatically returns to the neutral position.

⚠ CAUTION



Depending on the type of wood being split, a log may not always break into two pieces and fall to the ground. If a log sticks to the wedge, place the valve handle in the neutral position (stop the wedge from retracting) and carefully remove the log from the wedge. Allowing the log to remain attached to the wedge when it is fully retracted could lead to possible injury and/or damage to the log splitter.

Operation

Operation – Vertical Position

5. Use the following photos for the correct and incorrect methods of splitting logs. Never split a log using an incorrect or unsafe method.

⚠ WARNING



Before loading and operating the log splitter, always wear protective gear, such as safety goggles, face shield, hearing protection, tight-fitting gloves without draw strings or loose cuffs, and steel-toed shoes.

- a. To operate the log splitter in a vertical position, pull the spring-loaded locking lever and twist it either direction to lock it in the “unlocked” position.

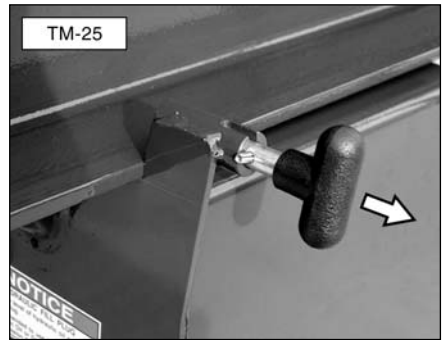

- b. Engage the parking brake on the tractor and stand the rail assembly up into a vertical position.



- c. Move the log under the splitting wedge keeping your hands on the sides of the log near the middle of the block. Center the log making sure that the sawed end is sitting on the large plate (base plate).



⚠ CAUTION



Do not place your hands on top of the log when loading the log splitter. This is a very **UNSAFE** method and could result in injury to your hands.



⚠ CAUTION



If you find you must hold the log until the wedge touches it and holds it in place, be very careful not to put your hand on top of the log. If you must, hold the log in the middle of the block. Remove your hand immediately when the wedge engages the log. Never use your hip or any extension device to operate the valve control handle.

- d. Hold the control lever, extending the splitting wedge, until the log is split or the cylinder rod stops at its maximum travel position. As the log is being split, **DO NOT** reach forward and attempt to catch the split wood — let it fall to the ground.

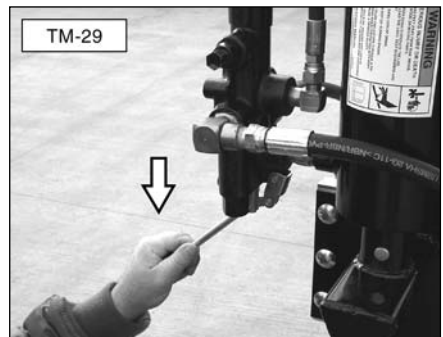

Operation

- e. Once the wedge reaches its full forward travel, pull back on the control lever to the full retract position. The ram of the cylinder will automatically retract into the cylinder. It is not necessary to hold the control lever as the cylinder retracts. Stop the wedge if the log sticks (see caution below). When the cylinder is fully retracted, the control valve will automatically shift to a neutral position.

- f. DO NOT load another log or remove split pieces from the rail until the wedge has completely stopped and the control handle automatically returns to the neutral position.

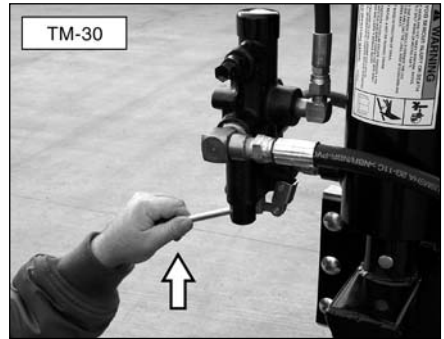

⚠ CAUTION



Depending on the type of wood being split, a log may not always break into two pieces and fall to the ground. If a log sticks to the wedge, place the valve handle in the neutral position (stop the wedge from retracting) and carefully remove the log from the wedge. Allowing the log to remain attached to the wedge when it is fully retracted could lead to possible injury and/or damage to the log splitter.

General Maintenance Check (before operating)

The hydraulic system (hoses, cylinder, and pump) should be carefully inspected before each use. Also, inspect the mechanical parts at the same time. Make sure all clamps, nuts, bolts, fittings, etc. are properly installed and tightened.

WARNING



Do not check for leaks with your hand. Leaks can be located by passing a piece of cardboard or wood around the suspected leak and looking for discoloration. High-pressure fluid escaping from a very small hole can be almost invisible. Escaping fluid under pressure can have sufficient force to penetrate skin, causing serious injury or even death. If fluid is injected into your skin, it must be treated immediately by a doctor familiar with this type of injury.

Always replace frayed, kinked, or cracked hoses and/or other damaged hydraulic components with Iron & Oak Commercial Products authorized parts and components specified in the "Parts" section of this manual. Replacement parts from secondary suppliers (not original Iron & Oak replacement parts) can lead to product damage and/or personal injury, and will void the warranty.

CAUTION



Do not remove the cap from the hydraulic tank or reservoir while the log splitter is running. Hot oil, under pressure, could be expelled resulting in serious injury.

Should it become necessary to loosen or remove any hydraulic fitting or line, be sure to relieve all hydraulic pressure by shutting off the tractor and moving the valve control handle back and forth several times until no cylinder movement is visible.

Storage

Between each use of the log splitter, we recommend applying a rust preventative (WD-40 or equivalent) to any bare metal areas on the top of the rail.

Specifications

Mechanical Specifications (Model TMVH02/PTO and TMVH03/HYD)

3-Point Hitch	Category 1, 2, or 3
Slide Rail	6" x 6" heavy-duty, H-beam
Wedge	9 inch, high-carbon steel, compound angle
Force/Tonnage	20 tons @ 3000 psi 12.5 tons @ 2000 psi 9 tons @ 1500 psi
Cylinder Stroke	24 inches
Log Opening	25 inch maximum
Operating Positions	Vertical/Horizontal
Pin Width	36 inches
Splitting Height (horizontal position)	30 inches
Unit Weight	575 lbs.

Hydraulic Specifications (Model TMVH02/PTO)

Cylinder Size	4 x 24 inch, clevis type cylinder with 1.75 inch rod
Hydraulic Tank Capacity	7.5 gallons
Hydraulic System Capacity (incl. cylinder, tank, hoses, and pump)	9.5 gallons
Safety Release Control Valve	Detent, auto return
PTO Pump	single-stage, 10 GPM

Hydraulic Specifications (Model TMVH03/HYD)

Cylinder Size	4 x 24 inch, clevis type cylinder with 1.75 inch rod
Hydraulic Tank Capacity	7.5 gallons
Hydraulic System Capacity (incl. cylinder, tank, hoses, and pump)	9.5 gallons
Safety Release Control Valve	Detent, auto return

Hydraulic Oil Specifications (non foaming) (Model TMVH02/PTO and TMVH03/HYD)

Tractor Hydraulic Oil	
Below 30° F	SAE 10W
Above 30° F	SAE 30W
Transmission Fluid	Dextron III

Important Notice

DO NOT mix tractor hydraulic oil with transmission fluid. Use one or the other.

The following section will detail procedures for checking your log splitter, should you encounter a malfunction. Iron & Oak Commercial Products, Inc. recommends that you do not attempt to make repairs to the log splitter. In the long run, it is better to take your log splitter to a servicing lawn and garden dealer for repairs.

Problem: When the control handle is pushed forward (extend), the wedge does not move.

1. On PTO models, check the hydraulic tank to make sure the oil level is at the bottom of the filler neck. Check tractor's hydraulic tank to make sure it is properly filled.
2. Make sure the PTO shaft on the tractor is turning. Make sure the PTO pump is pumping.
3. Make sure the tractor hydraulics are functioning.
4. Disconnect the wedge from the cylinder. Grasp the hydraulic cylinder shaft and try to pull it out. If the rod comes out easily, you will need to rebuild or replace the cylinder.

Problem: The wedge moves slowly, but will split wood.

1. Check the RPM of the PTO shaft or output of tractor's supply oil.
2. For PTO models check the output of the PTO pump.

Problem: The ram will not automatically retract.

1. Check the slide rail or wedge assembly for damage.
2. Push the valve handle to the retract position. If the handle will not stay in this position, adjust valve detent, as described below.

Detent Adjustment Procedure

- a. Locate adjustment screw on lower side of valve body.
 - b. Loosen locknuts.
 - c. Turn adjustment screw clockwise one-half turn and retighten locknuts.
 - d. Start PTO or tractor hydraulics and test for detent operation. If detent does not work, repeat Steps b and c.
3. If adjustment of detent does not correct the problem, replace the valve assembly.

Problem: Oil squirts from the fill plug during operation (PTO models only).

1. The oil tank may be over-filled. Drain oil to 1 inch below the filler neck.
2. The log splitter is not level. Make sure the log splitter is on level ground.

Decals

⚠ WARNING



Make sure all decals are attached to the log splitter and/or engine and are legible at all times.

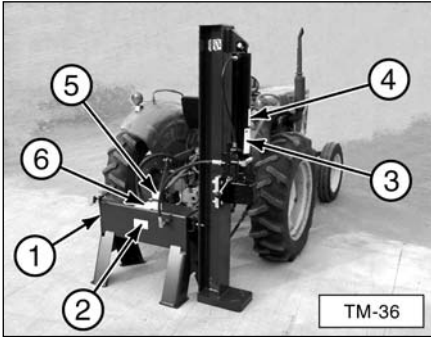

(3)



(1)



(4)



(2)



(5)

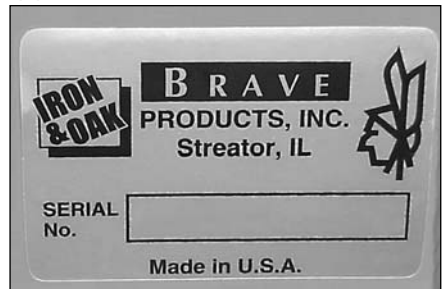

(6)

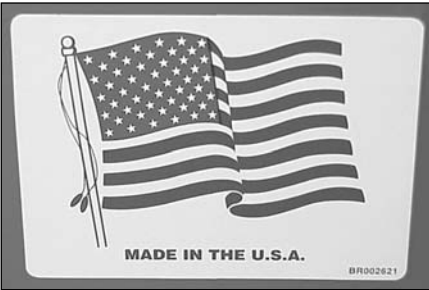

Item	Part No.	Description	Qty.
1	BR002652	Decal, Notice (hydraulic fill)	1
2	BR002557	Decal, Caution (base unit)	1
3	BR002558	Decal, Warning (cylinder)	1
4	BR002555	Decal, Caution (cylinder)	1
5	BR002521	Decal, Serial Number	1
6	BR002621	Decal, Made in USA	1
(NS)	—	Decal, Iron & Oak	1

NS - not shown

Parts

Model TMVH02/PTO

Item	Part No.	Description	Qty.
1	BR021282	Weldment, Base Tank	1
2	BR001703	Pin Assembly, Lift Arm	2
3	BR001406	Washer, Flat, 7/8" SAE	4
4	BR001022	Plug, Fill Vented	1
5	BR001025	O-ring, Vented Fill Plug	1
6	BR021396	Pin, Plunger	1
7	BR001090	Pin, Slotted Spring, 3/16" dia.	1
8	BR008151	Spring	1
9	BR008152	Knob, Bar	1
10	BR001460	Butt Hinge	1
11	BR001208	Bolt, 1/2-13 x 1-1/2" long	4
12	BR001404	Lockwasher, 1/2"	4
13	BR001304	Nut, 1/2-13	4
14	BR002004C	PTO Pump	1
15	BR020089	PTO Pump Handle	1
16	BR001251	Bolt, 3/8-16 x 1-1/2" long	2
17	BR001403	Lockwasher, 3/8"	2
18	BR008509	PTO Chain Assembly	1
19	BR005103	High-Pressure Hose, (PTO Pump to Valve As.)	1
20	BR001017	Fitting, High-Pressure, 90°	1
21	BR005083	Low-Pressure Hose, 48" long (PTO Pump to Base Unit)	1
22	BR004993	Clamp, Hose, No. 20	2

Item	Part No.	Description	Qty.
23	BR005102	Hose, High-Pressure (Bottom of Valve to Base Unit)	1
24	BR004119	Hose, High Pressure (Valve to Cylinder)	1
25	BR004002K	Fitting, 90° Elbow	1
26	BR001052	Fitting, Straight	1
27	BR004102	Valve	1
28	BR004152	Valve Link	1
29	BR004153	Pin, Clevis, 1/4 x 1" long	2
30	BR004154	Pin, Clevis, 1/4 x 3/4" long	1
31	BR004215	Pin, Cotter, 3/32 x 1/2" long	3
32	BR004102B	Handle, Valve	1
33	BR004102K	Knob	1
34	BR001241	End Cap	1
35	BR001027	Fitting, Straight	1
36	BR001242	Cap, Push On, 5/8" diameter	1

Parts

Model TMVH03/HYD

Item	Part No.	Description	Qty.
1	BR021283	Weldment, Leg	1
2	BR001703	Pin Assembly, Lift Arm	2
3	BR001406	Washer, Flat, 7/8"	4
4	BR021396	Pin, Plunger	1
5	BR001090	Pin, Slotted Spring, 3/16" dia.	1
6	BR008151	Spring	1
7	BR008152	Knob, Bar	1
8	BR001460	Butt Hinge	1
9	BR001304	Nut, 1/2-13	4
10	BR001404	Lockwasher, 1/2"	4
11	BR001208	Bolt, 1/2-13 x 1-1/2" long	4
12	BR004152	Valve Link	1
13	BR004154	Pin, Clevis, 1/4 x 3/4" long	1
14	BR004215	Pin, Cotter, 3/32 x 1/2" long	3
15	BR004153	Pin, Clevis, 1/4 x 1" long	2
16	BR004102B	Handle, Valve	1
17	BR004102K	Knob	1
18	BR004102	Valve	1
19	BR001241	End Cap	1
20	BR001052	Fitting, Straight	2
21	BR004002K	Fitting, 90° Elbow	1
22	BR004119	Hose, High Pressure (Valve to Cylinder)	1
23	BR001242	Cap, Push On, 5/8" diameter	1

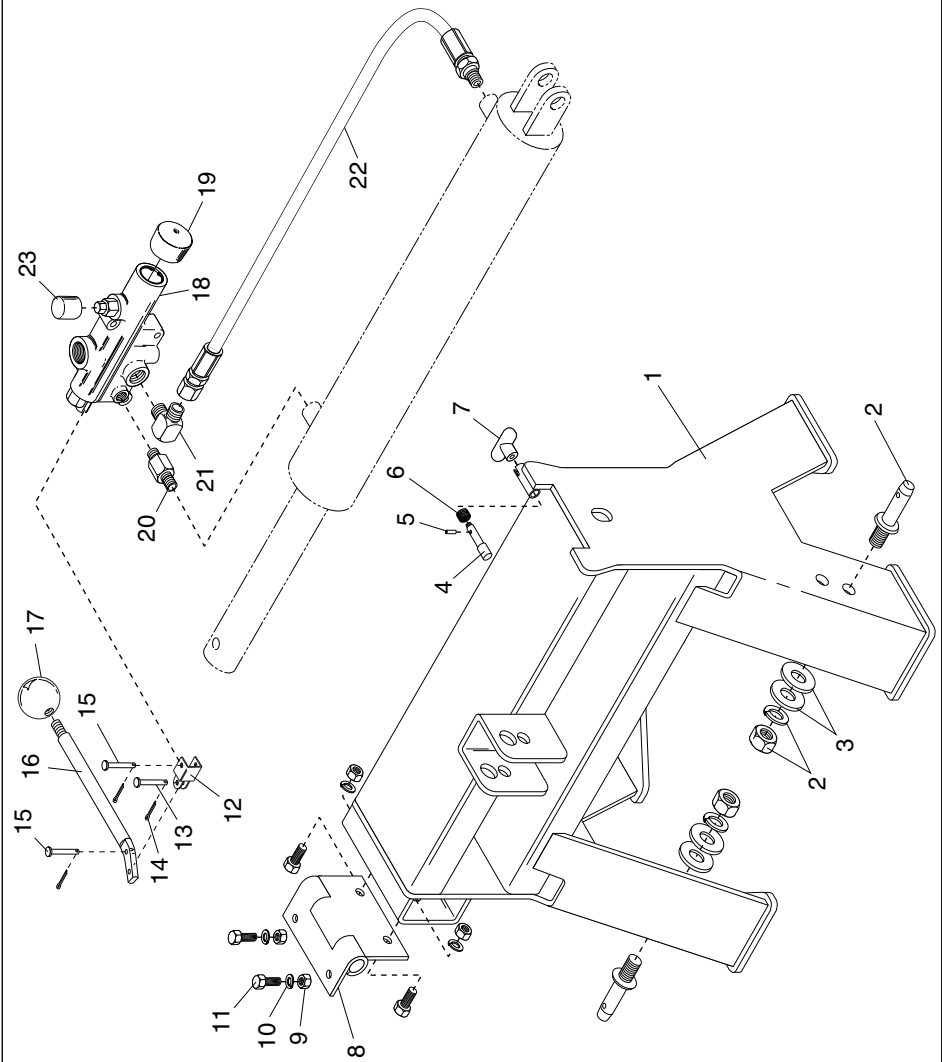

Parts

Model TMVH02/PTO and Model TMVH03/HYD

Item	Part No.	Description	Qty.
1	BR021264-08	Weldment, Rail	1
2	BR021163	Weldment, Slide Wedge	1
3	BR013102	Guide, Slide	2
4	BR013104	Retainer, Slide	2
5	BR001259	Bolt, Carriage, 1/2-13 x 2-1/2"	6
6	BR001404	Lockwasher, 1/2"	6
7	BR001304	Nut, 1/2-13	6
8	BR004057	Cylinder	1
9	BR001765	Pin, Clevis, 1/2 x 3" long	1
10	BR001761	Clip, Hairpin, 3/32 x 1-3/4" long	1
11	BR008531A	Pin, Grooved, 1" dia.	1
12	BR001705	Clip, Hairpin (Cylinder)	2

Note 1: Hole is used in this application (tractor mount models).

Note 2: Holes are used to mount optional BR021180 Log Cradle.

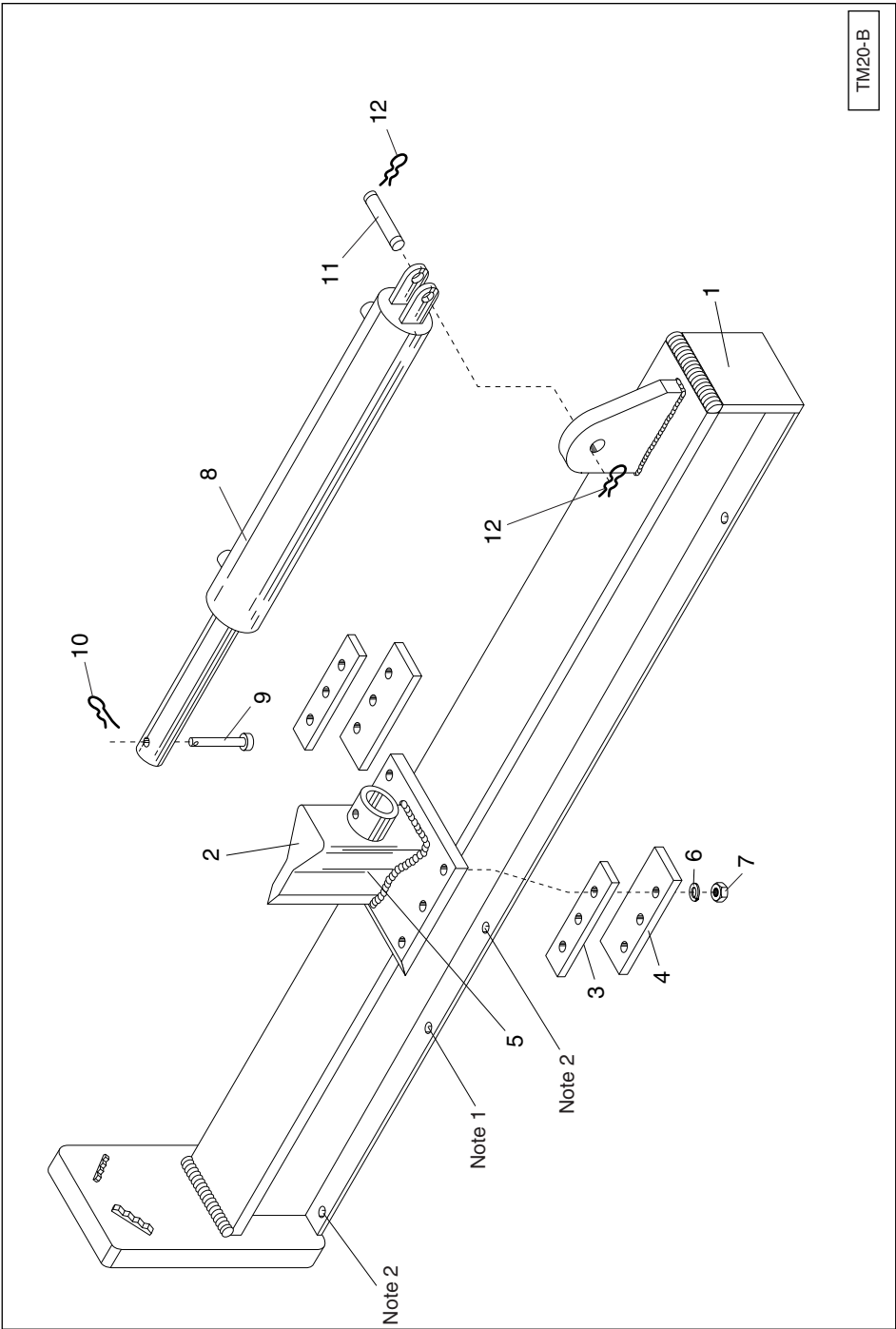

Warranty

For one year from the date of purchase, Iron & Oak Commercial Products Inc. will replace for the original purchaser, or repair free of charge, all parts of the Iron & Oak Commercial Products' Hydraulic Log Splitter, returned to our factory PREPAID and found upon inspection by us to be faulty, due to defects in materials or workmanship.

The warranty shall not apply to any unit which has been overloaded or misused or which has been installed, used, or operated contrary to our instructions, or which has been repaired or altered by anyone other than our authorized representative.

We shall not be liable for any contingent liabilities arising out of the improper function of any parts.

We make NO WARRANTY with respect to parts NOT of our manufacture, but we will carry out the terms of the warranties of their respective manufacturers.

If a service representative cannot be found in your area, call Iron & Oak Commercial Products at (815) 672-8596. Have your model and serial number on hand before calling.

Important Warranty Information

To activate your Iron & Oak log splitter warranty, please fill out the information in the form below, clip out the form on the dotted line, insert into an envelope, and mail to:

Iron & Oak Commercial Products, Inc
P.O. Box 577
Streator, IL 61364-0577

Iron & Oak Log Splitter Warranty Information

- Please Print -

Model: TMVH02/PTO or TMVH03/HYD SERIAL #: _____

OWNER'S NAME: _____

ADDRESS: _____

CITY: _____ STATE: _____ ZIP: _____

Purchased From: _____

Street Address: _____

City: _____ State: _____ Zip: _____

Your Signature: _____ Date: _____

Log Cradle (Part No. BR021180)

- ✓ Holds log in place on top of rail for faster splitting.
- ✓ Catches split logs - no more stooping to pick up the split pieces.
- ✓ Each shelf is infinitely adjustable up to 45 degrees to accommodate various sizes of logs.
- ✓ Mounts easily to H-beam rail - all hardware included, requires no drilling or welding on current model log splitters.

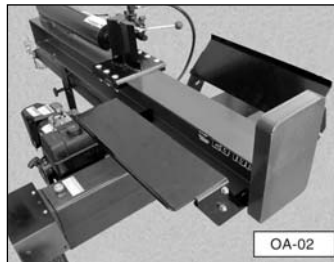
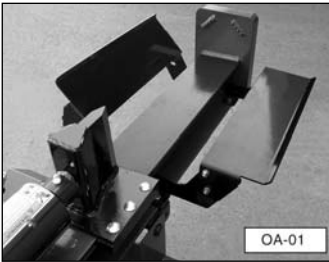

The log dislodger is designed to fit Iron and Oak Tractor Mount Log Splitters.

Log Dislodger (Part No. BR021171)

- ✓ Helps eject any log that sticks to the splitting wedge.
- ✓ Protects control valve and other hydraulic components from damage.
- ✓ Rugged construction to last the life of your log splitter.
- ✓ Mounts easily to splitter rail - all hardware included, no drilling or welding required.

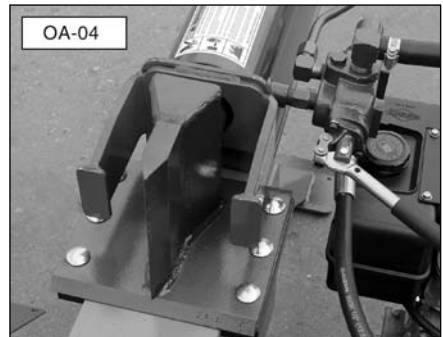

Notes



**COMMERCIAL
PRODUCTS™**

**Iron & Oak Commercial Products, Inc.
410 W. Broadway Ave.
Streator, Illinois 61364-0577
Phone: 815-672-8596
Fax: 815-672-9073
E-mail: sales@logsplitters-ironoak.com
Web Site: www.logsplitters-ironoak.com**